



Chicago Pneumatic™ SERVICE PARTS LIST

BULLETIN NO.
54-26-2000

SPECIFY CATALOG NO. AND SERIAL NO. WHEN ORDERING PARTS		REVISED BULLETIN	DATE
14.4 VOLT 3/8" SQUARE IMPACT WRENCH			July 2003
CATALOG NO. CP8730	STARTING SERIAL NO. A33A	WIRING INSTRUCTION 58-01-1835	

EXAMPLE:

00/0

Component Parts (Small #) Are Included When Ordering The Assembly (Large #).

6/3

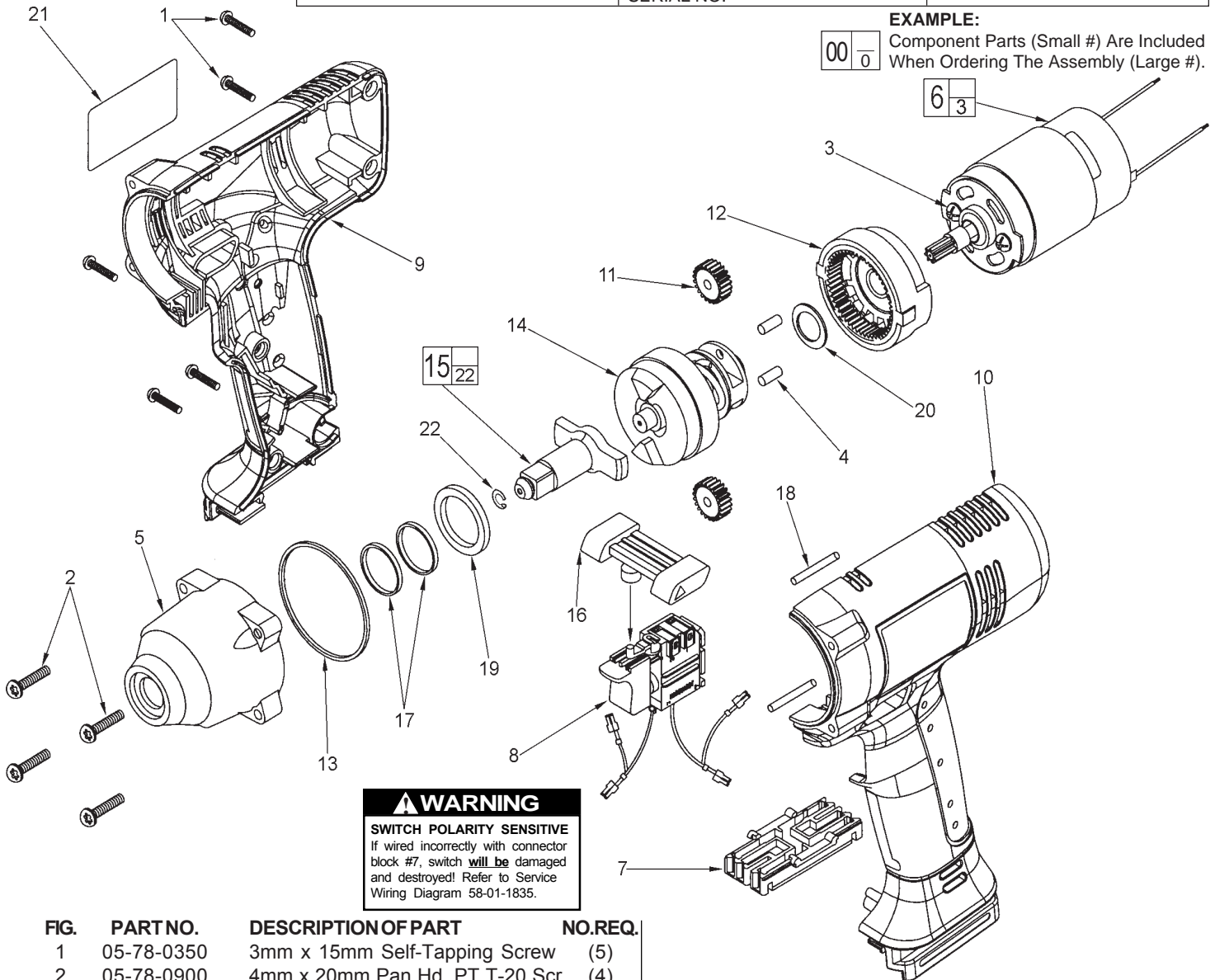

⚠ WARNING
SWITCH POLARITY SENSITIVE
 If wired incorrectly with connector block #7, switch **will be** damaged and destroyed! Refer to Service Wiring Diagram 58-01-1835.

FIG.	PARTNO.	DESCRIPTION OF PART	NO.REQ.
1	05-78-0350	3mm x 15mm Self-Tapping Screw	(5)
2	05-78-0900	4mm x 20mm Pan Hd. PT T-20 Scr.	(4)
3	05-81-0409	4mm x 8mm Pan Hd. Machine Screw	(2)
4	06-65-0970	4mm x 10mm Pin	(2)
5	14-30-0575	Gearcase Assembly	(1)
6	14-50-0720	Motor Assembly (Includes item 3)	(1)
7	22-56-0195	Connector Block	(1)
8	23-66-2247	Switch Assembly	(1)
9	31-44-1405	Right Housing	(1)
10	31-44-1410	Left Housing	(1)
11	32-62-0230	Planet Gear	(2)
12	32-65-0100	Ring Gear Assembly	(1)
13	34-40-0960	Rubber Ring	(1)
14	38-50-0930	Middle Shaft Assembly	(1)
15	42-06-0475	Output Shaft Assembly	(1)
16	45-24-0520	Forward/Reverse Lever	(1)
17	45-06-0750	Felt Washer	(2)
18	45-06-0760	0.8mm x 20mm Seal	(2)
19	45-88-0805	Washer	(1)
20	45-88-0955	Washer	(1)
21	12-20-1090	Service Nameplate Kit	(1)
22	34-60-1030	Retaining Ring	(1)

FIG. LUBRICATION:

- 6 Lightly coat the pinion area of the motor assembly with Type "L" grease, No. 49-08-4170.
- 12 Lightly coat the inside surface of the ring gear assembly with Type "L" grease.
- 4,11, 14,15,20 Lightly coat the surfaces of the pins, planet gears, middle shaft assembly, output shaft assembly and washer with Type "L" grease.

MILWAUKEE ELECTRIC TOOL CORPORATION
 13135 W. LISBON RD., BROOKFIELD, WI 53005
 Drwg. 2